



Storage Solutions



5  colours available

Knowledge In Design And Engineering

Every SquireRack Mobile Filing System is carefully designed and constructed in the highest quality, precision engineered using specially selected materials for its strength, integrity and durability. Paying attention to details, these attributes are critical considerations embraced by our R & D engineers when designing a storage system to withstand very heavy loads are concerned.

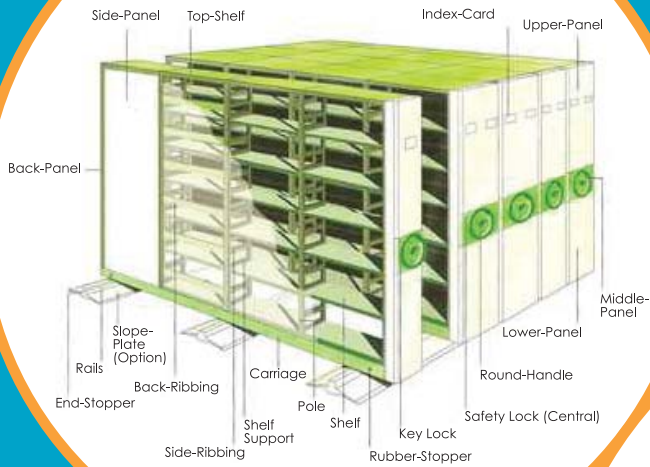

Strength and Durability

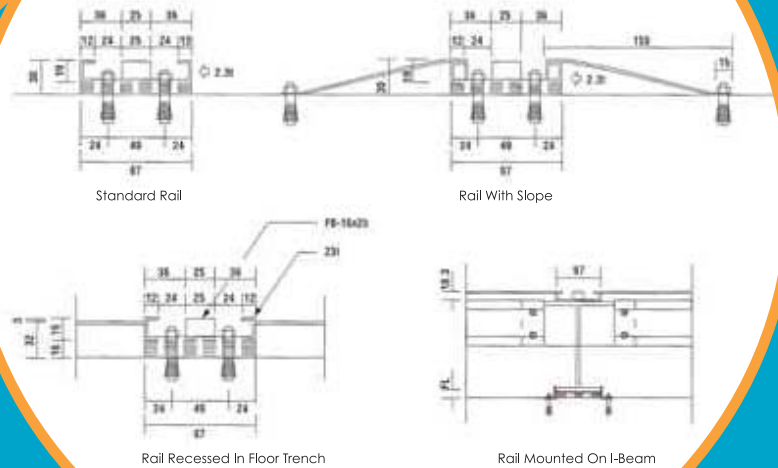

Technical Informations

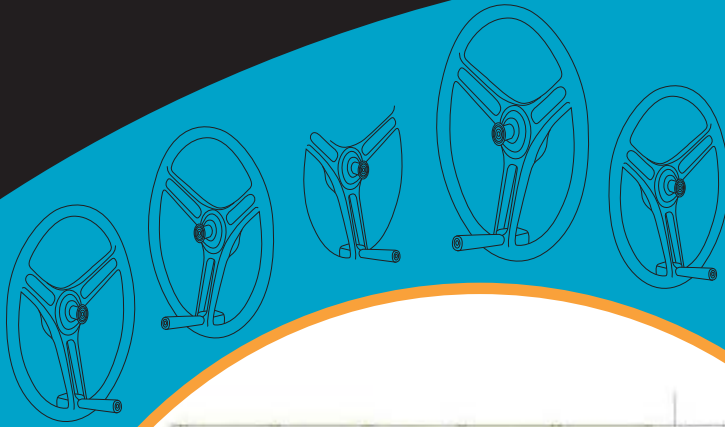

Specifications:

Height (From Floor Level)

- (H) 1844 m/m (6 Feet) - 4 Tiers Per Bay
- (H) 2174 m/m (7 Feet) - 5 Tiers Per Bay
- (H) 2444 m/m (8 Feet) - 6 Tiers Per Bay

Standard Shelf Size

- (D) 220 x (W) 860 x (H) 30 m/m
- (D) 270 x (W) 860 x (H) 30 m/m
- (D) 310 x (W) 860 x (H) 30 m/m
- (D) 365 x (W) 860 x (H) 30 m/m
- (D) 420 x (W) 860 x (H) 30 m/m

Loading capacity: 70 Kg UDL Per Shelf

Length (Overall)

- (L) 1105 m/m (1 Bay Depth)
- (L) 2005 m/m (2 Bay Depth)
- (L) 2905 m/m (3 Bay Depth)
- (L) 3805 m/m (4 Bay Depth)
- (L) 4705 m/m (5 Bay Depth)
- (L) 5605 m/m (6 Bay Depth)
- (L) 6505 m/m (7 Bay Depth)
- (L) 7405 m/m (8 Bay Depth)
- (L) 8305 m/m (9 Bay Depth)
- (L) 9205 m/m (10 Bay Depth)

Width (Front)

- (W) 352 m/m (S.S.F)
- (W) 407 m/m (S.S.F or S.S.M)
- (W) 462 m/m (S.S.F or S.S.M)
- (W) 482 m/m (D.S.F or D.S.M)
- (W) 582 m/m (D.S.F or D.S.M)
- (W) 602 m/m (D.S.F or D.S.M)
- (W) 662 m/m (D.S.F or D.S.M)
- (W) 772 m/m (D.S.F or D.S.M)
- (W) 882 m/m (D.S.F or D.S.M)

S.S.F : Single-Sided Fixed Row
D.S.F : Double-Sided Fixed Row

D.S.M : Double-Sided Mobile Row
S.S.M : Single-Sided Mobile Row

Direct-Drive System And Railing Layout

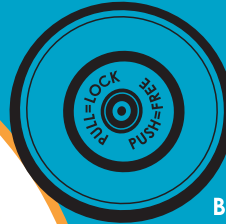
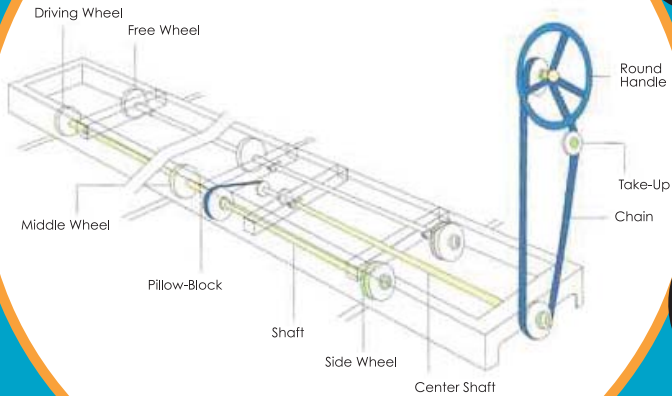

Bay Depth With Rail Positions

Bay Depth	1	2	3	4	5	6	7	8	9	10
Numbers Of Railings	2	2	2	3	4	4	5	5	7	7



- The SquireRack Mobile Filing System employs a Direct-Driven chain network, efficiently incorporating a full set of carefully integrated interconnecting solid steel shafts, pillow blocks, pinions and industrial graded gears and chain network which will be transmitted to the castors via rotation of operating handle by users. It is propelled by a circular handle which reduces the gearing ratio against load and effort required to operate the fully-loaded system.
- Rugged steel under-carriage construction and maintenance-free double flanged solid steel castors ensure strong support and equal weight distribution.
- An innovative track system design that provides for an easy and almost effortless operation.

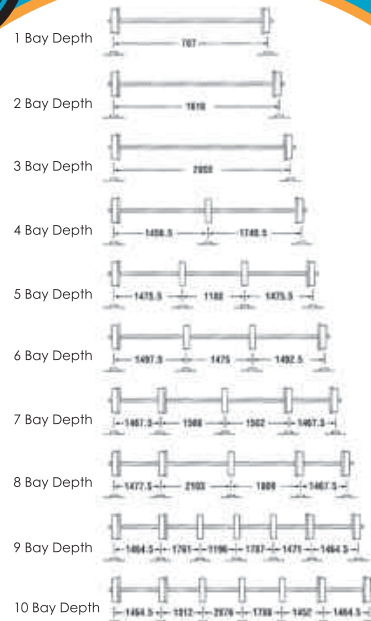

COMMITMENT



PRIDE



CREATIVITY



PROFESSIONALISM



SOLUTIONS



INTEGRITY



AT SQUIREGROUP, WE PROVIDE YOU WITH THE BEST STORAGE SOLUTIONS





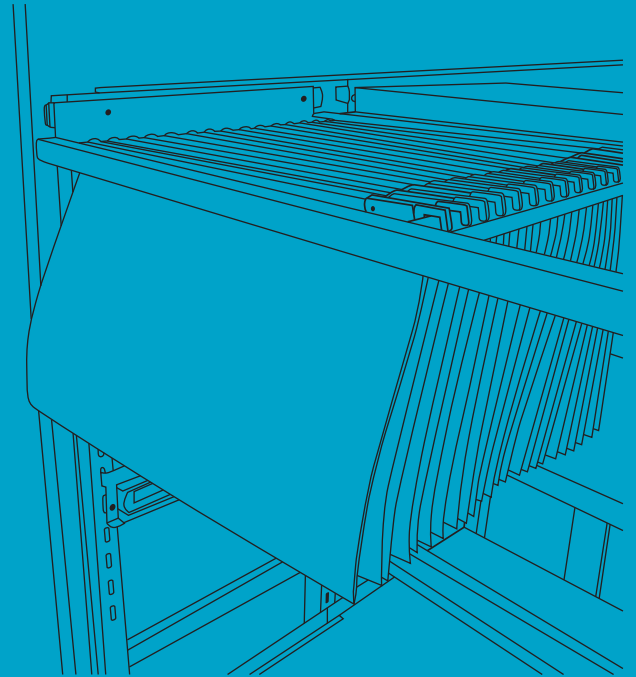
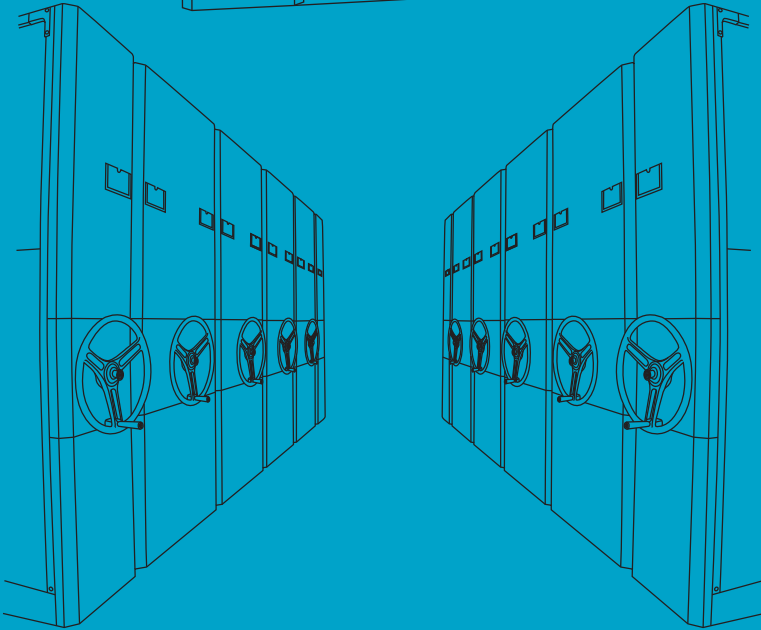
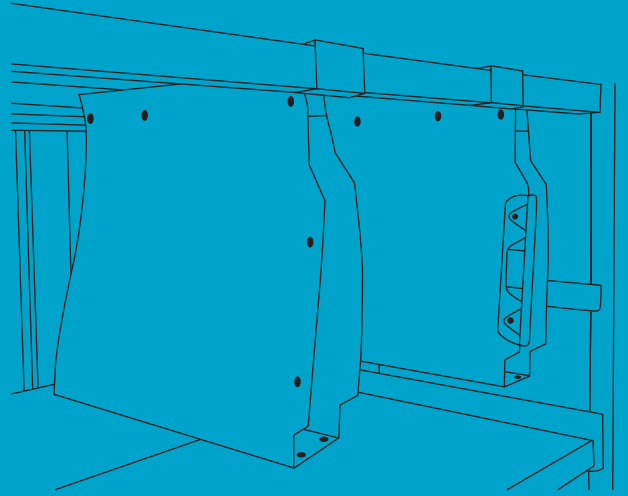



- Other dimensions available upon request.
- Various colours and different surface finishes available.

This catalogue has been designed for distribution throughout international markets. As such, some specifications and technical information contained herein may not apply in all markets. All information featured in this catalogue have been thoroughly checked and are correct at the time of printing. Squiregroup reserve the rights to amend, change, correct, replace or update all or any specifications or illustrations in this catalogue for the furtherance of product improvement and refinement.

